

www.maestrispa.it

MAESTRI

DIESEL TANK

TRANSPORTABLE DIESEL/BIODIESEL FUEL TANK
TOTALLY EXEMPT FROM ADR 1.1.3.1.C REGULATION



MAESTRI

DIESEL TANK

I2V and 24V Battery - 40 L/MIN.

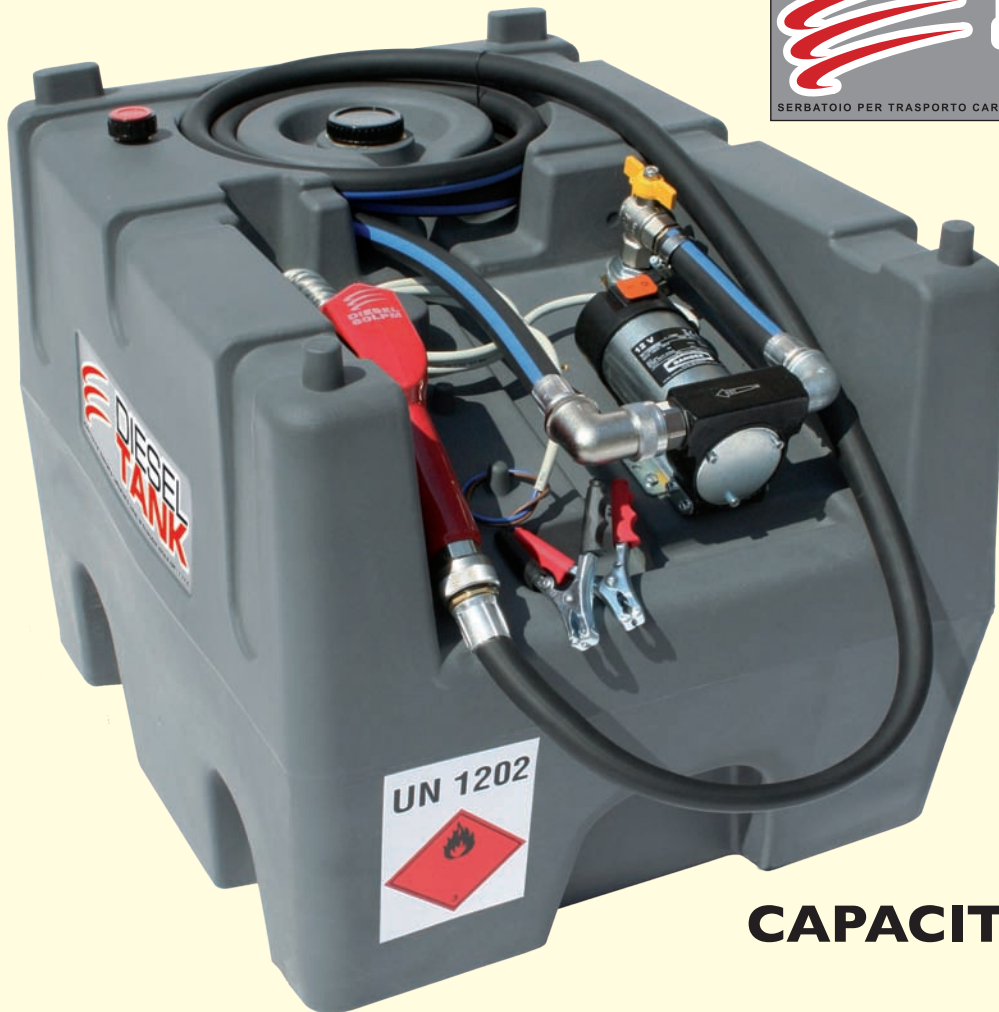

CAPACITY 125 LITERS

Mod. **I25DT/I2V**

DIESEL/BIODIESEL fuel tank totally exempt from ADR 1.1.3.1.C regulation.

Capacity 125 liters. Complete with 12V electric pumps (40 L/Min), 4m electric cable and clamps, On/Off Switch, rigid suction pipe with foot valve, security valve, 4m discharge hose with automatic fuel nozzle. Lock not included

Net weight: 21.50kg - Material: **PEHD**

Mod. **I25DT/24V**

DIESEL/BIODIESEL fuel tank totally exempt from ADR 1.1.3.1.C regulation.

Capacity 125 liters. Complete with 24V electric pumps (40 L/Min), 4m electric cable and clamps, On/Off Switch, rigid suction pipe with foot valve, security valve, 4m discharge hose with automatic fuel nozzle. Lock not included

Net weight: 21.50kg - Material: **PEHD**

Mod. **I25DT/I2V/DGT3500**

DIESEL/BIODIESEL fuel tank (12V pump) complete with electronic flow meter

Mod. **I25DT/24V/DGT3500**

DIESEL/BIODIESEL fuel tank (24V pump) complete with electronic flow meter



DIESEL TANK I25 - 40L/MIN.

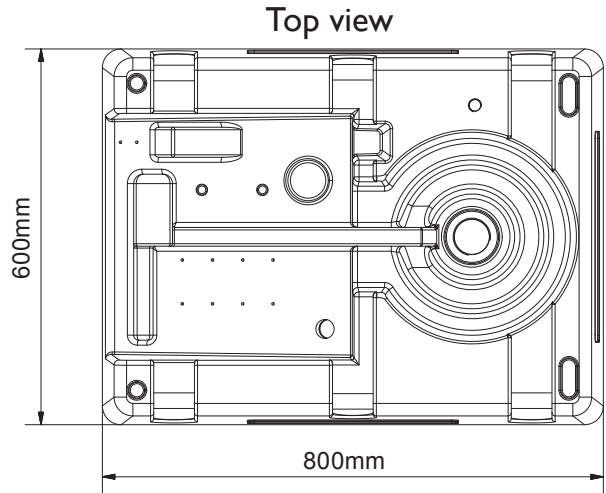
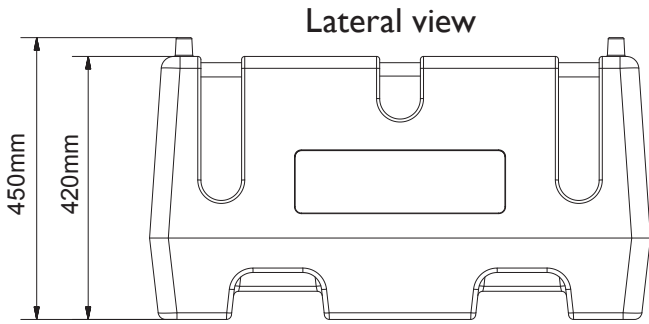

Optional:

Mod. I25DT/CFC

Lockable cover

Net weight: 16.50kg

Lock not included



**CAPACITY 220 LITERS****Mod. 220DT/12V**

DIESEL/BIODIESEL fuel tank totally exempt from ADR 1.1.3.1.C regulation.
Capacity 220 liters. Complete with 12V electric pumps (40 L/Min), 4m electric cable and clamps, On/Off Switch, rigid suction pipe with foot valve, security valve, 4m discharge hose with automatic fuel nozzle. Lock not included
Net weight: 26.50kg - Material: **PEHD**

Mod. 220DT/24V

DIESEL/BIODIESEL fuel tank totally exempt from ADR 1.1.3.1.C regulation.
Capacity 220 liters. Complete with 24V electric pumps (40 L/Min), 4m electric cable and clamps, On/Off Switch, rigid suction pipe with foot valve, security valve, 4m discharge hose with automatic fuel nozzle. Lock not included
Net weight: 26.50kg - Material: **PEHD**

Mod. 220DT/12V/DGT3500

DIESEL/BIODIESEL fuel tank (12V pump)
complete with electronic flow meter

Mod. 220DT/24V/DGT3500

DIESEL/BIODIESEL fuel tank (24V pump)
complete with electronic flow meter





DIESEL TANK

12V and 24V Battery - 40 L/MIN.

DIESEL TANK 220 - 40L/MIN.

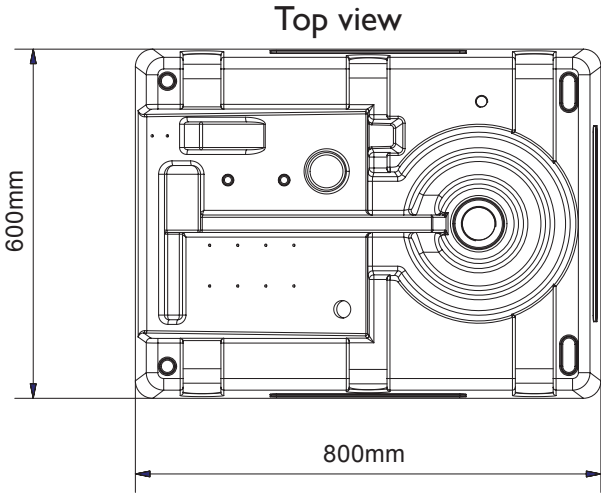
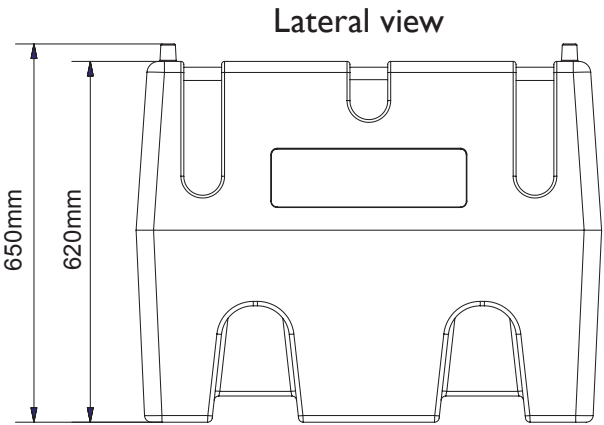

Optional:

Mod. 220DT/CFC

Lockable cover

Net weight: 16.50kg

Lock not included



MAESTRI

DIESEL TANK

12V and 24V Battery - 40 L/MIN.



DIESEL TANK 430

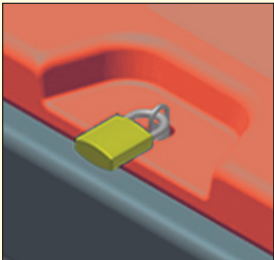

UN 1202
SERBATOIO IN POLIETILENE
PER TRASPORTO CARBURANTE DIESEL
IN ESEZIONE TOTALE ADR 1.1.3.1.C

CAPACITY 430 LITERS

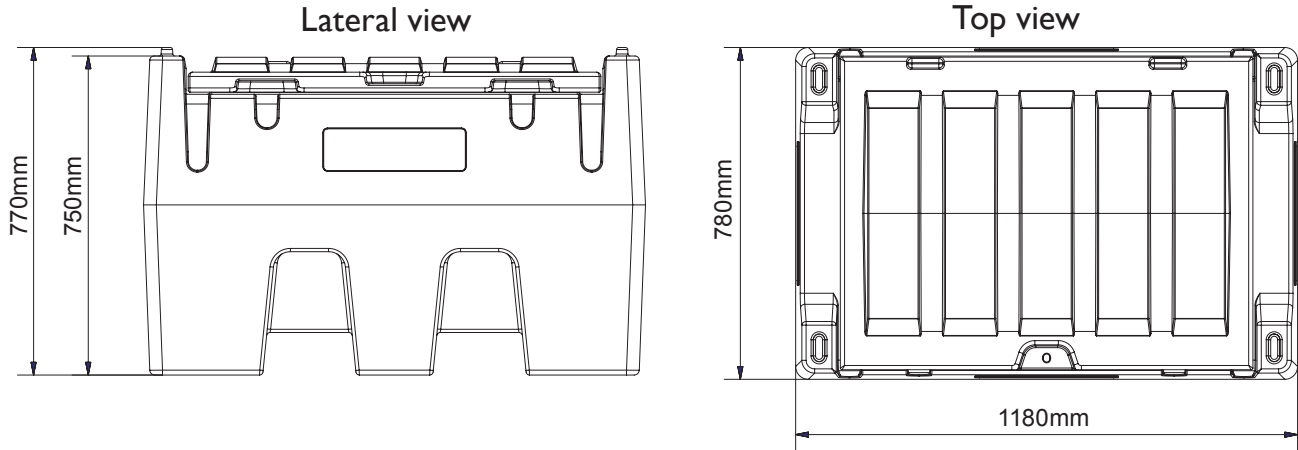
DIESEL TANK 430 - 40L/MIN.**CAPACITY 430 LITERS****Mod. 430DT/12V**

DIESEL/BIODIESEL fuel tank totally exempt from ADR I.1.3.1.C regulation.

Capacity 430 liters.

Complete with 12V electric pumps (40 L/Min), 4m electric cable and clamps, On/Off Switch, rigid suction pipe with foot valve, security valve, 4m discharge hose with automatic fuel nozzle. Control level.

Lock not included.

Material: **PEHD**

Mod. 430DT/24V

DIESEL/BIODIESEL fuel tank totally exempt from ADR I.1.3.1.C regulation.

Capacity 430 liters.

Complete with 24V electric pumps (40 L/Min), 4m electric cable and clamps, On/Off Switch, rigid suction pipe with foot valve, security valve, 4m discharge hose with automatic fuel nozzle. Control level.

Lock not included.

Material: **PEHD**

Mod. 430DT/12V/DGT3500

DIESEL/BIODIESEL fuel tank (12V pump)
complete with electronic flow meter

Mod. 430DT/24V/DGT3500

DIESEL/BIODIESEL fuel tank (24V pump)
complete with electronic flow meter





MAESTRI S.p.a.
VIA PIACENZA, 31
43126 PARMA (Italy)
Tel. +39 0521 993741 - Fax +39 0521 994671
E-mail: maespr@tin.it - www.maestrispa.it

EQUIPAGGIAMENTI PER LA MECCANIZZAZIONE